

Product Overview

The Digi-Gage 2400 is a level monitoring system capable of controlling up to four pumps or measuring wet wells and tank levels. This exceptional versatility has been proven in a broad spectrum of applications ranging from critical control of tank levels to monitoring effluent flow in pumping stations.

The Digi-Gage delivers the control efficiency and productivity needed to meet today's exacting standards. The system uses an internal pressure transducer (15 psi max) or a remote mounted submersible pressure transducer to monitor water and wastewater.

Other models are available to handle a variety of liquid level control requirements:

- Digi-Gage 2300 for up to 3 pumps in a duplex or triplex configuration (constant speed).
- Digi-Gage 2600 for up to 6 pumps in a five-plex or six-plex configuration (constant speed).
- Vari-Gage 3300 for up to 3 pumps in a duplex or triplex configuration (constant or variable speed).

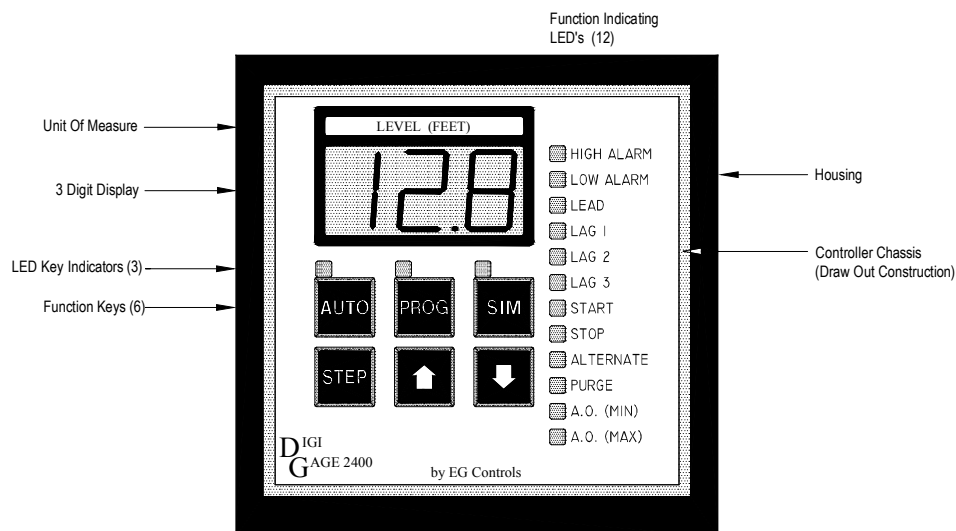

Product Features

- ◆ Easy to configure for simplex, duplex or triplex applications
- ◆ Program with only three simple steps!
- ◆ No wires or pneumatic connections to disconnect
- ◆ Three field selectable inputs: 4-20mA; 0-10V, 0-15 psi
- ◆ NEMA 1 housing
- ◆ Easy to read 1/2" high 7 segment LED
- ◆ Differential level control
- ◆ Level indication (0 – 999 max)
- ◆ 15 discrete LED's for Mode/Status indication
- ◆ EEPROM (electrically erasable programmable read only memory) lasts for 100 years – no battery back-up required
- ◆ Draw-out chassis construction
- ◆ Pneumatic connector accepts standard 1/4" OD flex tubing
- ◆ Pump up or pump down capability
- ◆ Manual or automatic alternation
- ◆ Performs self-diagnostics upon power up to maintain optimum status
- ◆ MODBUS communications capability

- ◆ Lag pump start delay of ten seconds
- ◆ 100% digital technology -- virtually eliminating all sources of drift or error.
- ◆ Level simulation by using UP and DOWN arrow keys
- ◆ Works with Scada Express for implementation of remote station monitoring and control.

Manufacturer Information

The Digi-Gage is exclusively available from:



11790 Phillips Highway
Jacksonville, Florida 32256
Telephone: 904-292-0110 Fax: 904-292-0119
Email: sales@egcontrols.com
Visit our website at www.egcontrols.com

➔ Typical Wiring Diagram for DG2400-232-24AC

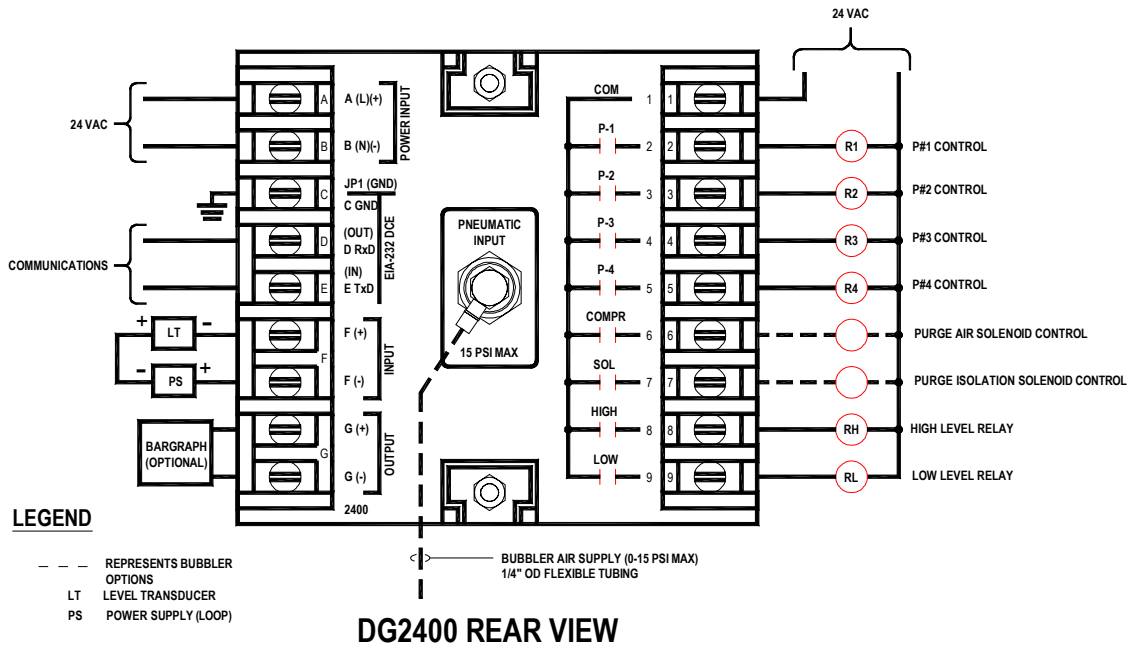

Technical Specifications

Input Power:

24VAC, 8.5 VA, 350mA

Environment:

Ambient Temperature (-10°C to 70°C)

Display Range:

Keypad selectable, 0-999, 0-99.9, 0-9.99, 0-.999

Resolution:

0.006%, 14 bit A/D

Input Options:

4-20mA (50 Ω impedance)
0-10 VDC (>150K Ω impedance)
0-15 psi (clean, dry air only)

Memory:

NOVRAM EEPROM 100 Year Memory. No batteries needed

Programming:

Via front panel function keys

Display:

.5" high 7 segment red LED, 3 digit

Housing:

Type 1, NEMA 1

Discrete Outputs:

8 contacts, SPST, 1A@120VAC
4 pumps, 2 alarms (high and low)
2 bubbler controls (isolate and purge)

Analog Output:

4-20mA (600 Ω load max)

Linearity:

+/- .005% analog output; +/- 0.1% pneumatic input

Dimensions

Dimensions:

3.78" x 3.78" x 7.32"

Depth behind panel:

6.4" max

Panel Cutout:

3.6" x 3.6"

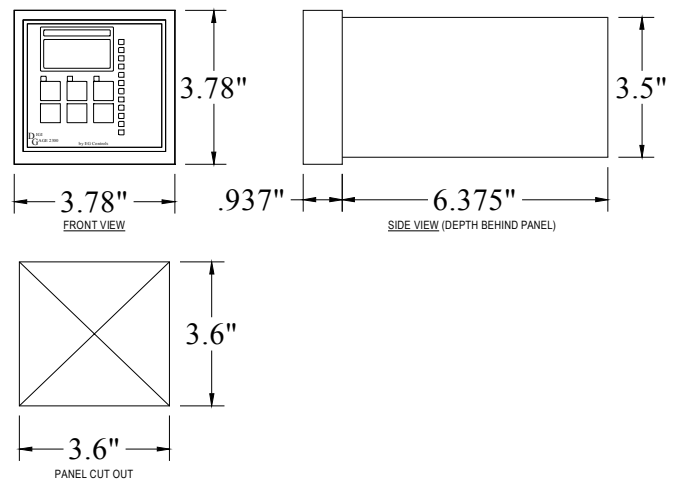

JACKSONVILLE, FLORIDA

11790 Philips Highway

Jacksonville, Florida 32256

Telephone: 904-292-0110 Fax: 904-292-0119